



SAFETY INSTRUCTIONS

WARNING:

To avoid mistakes that could cause injury, do not use the Multitool until you have read and understood the following:

- ALWAYS WEAR EYE PROTECTION.** A full-face visor is preferred. Any Belt/Disc Grinder can throw foreign objects into the eyes
- AVOID CONTACT** with Belt or Disc. The abrasive belt when running is an aggressive cutting tool. Extra care should be exercised when using coarse grit belts because of their rapid cutting action.
- KEEP CHILDREN AWAY.** All visitors should be kept a safe distance from the work area.
- BOLT THE BENCH GRINDER** securely to the bench or supporting surface to stop it from tipping over or moving when in use.
- DO NOT MOUNT** the attachment protruding into walkways.
- KEEP WORK AREA CLEAN.** Cluttered areas and benches invite accidents.
- ALWAYS WEAR A DUST MASK** to prevent dust inhalation when adequate ventilation or extraction is not available.
- DO NOT WEAR LOOSE CLOTHING,** which may become entangled in the machine. Wear protective hair covering to contain long hair.
- ALWAYS HOLD** the work piece firmly when grinding and apply a light and steady pressure against abrasive disc or belt.
- ALWAYS GRIND ON THE DOWNWARD SIDE** of the grinding disc. Grinding on the upward side of the disc could cause the work piece to fly out of position, resulting in injury.
- DO NOT USE** belts that are damaged, torn or show signs of wear.
- ALWAYS INSTALL BELTS** with arrows in the back of the belts facing the correct direction. Belts and lap joints must be fitted facing the correct direction. See sketch below.

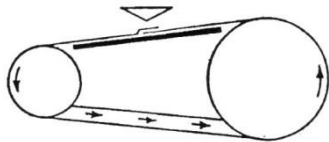

INTRODUCTION TO BELT GRINDING

Belt grinding or finishing has many advantages over the use of conventional grinding wheels. It is possible to remove material up to 5 times faster than the equivalent grade of grinding wheel with far less heat. The electrostatic process used in the manufacture of an abrasive belt ensures that the sharp side of each piece of grit is facing outwards on the belt thus giving cleaner, smoother and faster cutting. The flexing of the belt has a self cleaning action and also it does not overheat, making it more suitable to any application where heat could damage the work, for example, grinding leather, plastics, tool sharpening etc

BELT APPLICATIONS

ALL METALS	COARSE FINISH	Use 40 to 80 Grit aluminium Oxide Belts
	MEDIUM TO FINE	Use 100 to 80 Grit
	VERY FINE	Use 250 to 400 Grit
Grit	MICROFINISHING	Use 3M Trizact 600 to 2000
	HEAVY GRINDING OR THIN SECTIONS	Use Zirconia Belts 40,60,80
ALUMINIUM	Always use belt grease to prevent clogging.	
WOOD	Use Aluminium Oxide Resin Bont open or close 40, 60, 80, 100, 120	
PLASTICS & GLASS CERAMIC	Use Silicon Carbide Resin Bond 40 to 600 Grit 7.5	

AVAILABLE ACCESSORIES

- ADJUSTABLE ANGLE WORK TABLE for Disc Grinding
- SHARPENING JIG – for sharpening chisels to 2" (51mm) plane blades to 2 3/4" (60mm) power planer blades to 3 1/4" (82mm) and re-tipping screwdrivers – professional results. Fits all Multitool Models except 8CW.
- BELT GREASE – to prevent clogging on aluminium and other soft metals.
- BELT CLEANING STICK – removes wood or grease build up – prolongs belt life.
- POLISHING COMPOUND - for use with type T Belts

OPERATING INSTRUCTIONS**BELT CHANGING**

To remove the belt simply push down on the underside of belt to compress the tensioner assembly. Catch automatically holds slide in retracted position. When refitting the belt simply release the catch (Fig 3: O). Always make sure belt lap faces the correct direction (see diagram left).

BELT TRACKING

Always ensure the belt entirely covers the rubber contact wheel. Adjustment is made when running or when belt is rotated by hand. To adjust left, move tracking lever down. To adjust right, move lever up. If tracking lever is constantly set in up or down position refer to (Figs 5 & 6: N) of fitting instructions on reverse side.

PLATEN GRINDING (HORIZONTAL OR VERTICAL)

It is important that Platen (Fig 4: P) is not set too high. If belt is deflected and rides up over the platen it creates an undue strain on the grinder, especially when starting. If platen is not often used it is better to set a little clear of the belt. A simple method to adjust the platen is to place a straight edge on top of the belt between the contact wheel and drive pulley and raise platen so that it just touches under side of belt. Work of any length can be surfaced on the platen, for example the sawn edges of wood from short pieces up to lengths of several metres. Never grind or sand on platen unless you are sure belt lap is facing in correct position (See diagram at left).

DISC GRINDING

Whenever possible remove the belt when using the disc facility. The disc grinding facility is a very useful and versatile part of the attachment. It is very useful for dressing small castings and components, patterns, models etc., often eliminating costly machining. Tool and cutter sharpening is a simple task and there is less chance of burning edges. With the addition of the table, lengths and angles are easy to adjust. Dressing end grain flat and square has always been a difficult task but now it is a simple and quick operation, making perfect joints possible. A rubber cleaning stick should be used regularly to prevent build up wood resin. Three options are available in abrasive discs. 1. Self-Adhesive. 2. Fur backed – which must be used with an optional hook and loop backing pad. 3. Plain paper or cloth backed disc which must be attached with a contact adhesive. When changing a disc pad remove any remaining adhesive with a solvent, e.g. Lacquer thinner, acetone (nail polish remover). Do not use household cleaners.

CONTACT WHEEL GRINDING POLISHING AND SANDING

Using the front contact wheel avails the user of material removal many times faster than a conventional grinding wheel. The unique smooth cutting action is cooler, faster and safer than conventional grinding methods. A good example of one of the many uses is the smoothing of welds and casting blemishes prior to plating. Using the extremely fast and easy belt change it is possible to go from a rough weld finish to a flat, smooth polish suitable to chrome plate in only two belt changes. e.g. Remove rough weld with 40, 60 or 80 grit belt. Remove grinding marks – 240 grit belt. Change ground finish to smooth, brushed finish for plating – Scotchbrite super fine. Wood shaping and finishing can be done in a similar manner but belts should always be kept exclusively for wood, especially in the finer grades. A rubber belt cleaning stick helps prevent clogging on wood use.

FREE STRAPPING

Free strapping is a method of belt grinding, sanding or polishing where no backing is used behind the belt. It is especially suitable for round and contoured work and some sharpening operations. It is done on the underneath side of the belt opposite the platen. Belt grades of 180 to 400 are recommended because of the rapid cutting action.

SPECIFICATIONS**MULTITOOL 362**

Belt size 36" x 2" (915 x 50) Disc size 7" (178) Contact Wheel 3 1/2" (89) dia. Suits most 6" (150) or 8" (200) bench grinders with minimum 1/2 H.P. (248W) and Shaft sizes of 1/2" & 5/8" **RATING** Continuous Industrial

MULTITOOL 482 & MULTITOOL 8CW

Belt size 48" x 2" (1220 x 50) Disc size 7" (178) Contact Wheel 3 1/2" (89) dia. 8CW Model. Suited to 8" (200) bench grinders with minimum 1/2 H.P. (373W) and Shaft size of 5/8"

BELT SPEED – ALL MODELS

AUSTRALIA	4200 Ft/min (1280 metres/min)
USA	5000 Ft/min (1524 metres/min)

WARRANTY AND CONDITIONS OF SALE

The words "us", "we" or "our" refers to P.A Products or their authorized agent

- The warranty will only apply if the fitting and operating instructions are followed.
- The warranty does NOT apply for a period of 1 year from the date of original purchase against any defect in our product, which can be proved, to our satisfaction to have been caused by faulty materials or workmanship. Our liability is limited to the cost of repairing or at our option, replacement of the defective goods or parts of the goods. We will not be liable for any defect caused by unauthorized repair.

INSTRUCTIONS TO FOLLOW FOR WARRANTY CLAIMS:

- If warranty claim is made, we must be notified as soon as possible after assumed defect has become apparent.
- Goods may only be returned for credit with the approval of PA Products in Australia Ph. +61-2-6337-1142.
- The customer must prepay all freight charges for returned goods.
- We will contact the customer with an advice after inspecting the goods to determine with the customer what action should be taken in the circumstances.

FITTING INSTRUCTIONS — ALL MULTITOOL MODELS

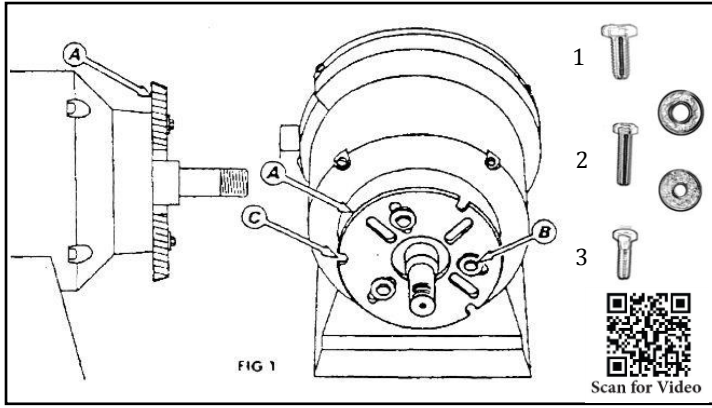

From the right hand end of the grinder, remove wheel cover, wheel, wheel flanges and wheel guard. Fit slotted adaptor plate (A) using either 1/4" bolt (1), 5mm Bolt (2) or 3/16" Bolt (3) provided. Use appropriate size washers under heads (B). **The outer edge of the adaptor plate is tapered. Face smallest side of taper away from grinder as shown in Fig 1. (A)**

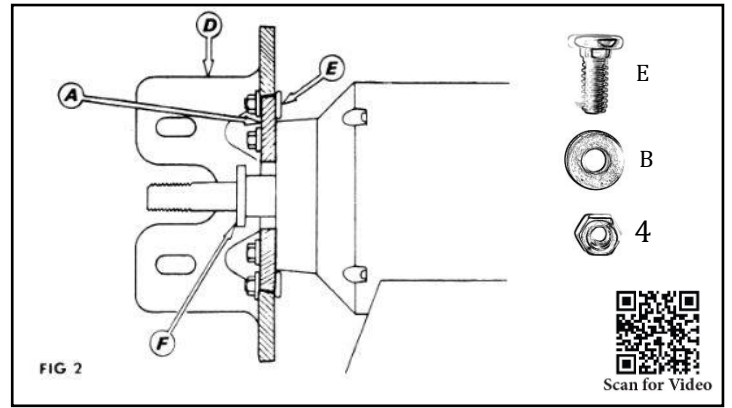

Fit the Main Bracket (D) using flat head clamp bolts (E) through the 3 slots (Fig 1: C) in outer edge of the adaptor plate, with flat heads of bolt facing the grinder. With angle face of bracket approximately vertical, tighten 1/4" nuts (4) evenly. The adaptor plate should be flush with the main bracket. If the Multitool is to be used in a vertical position simply loosen nuts, tap main bracket (D) to loosen. Swivel to desired position and retighten nuts (4). The above cutaway view is from the rear of the right hand end of the grinder showing the tapered fit of the adaptor plate (A) and main bracket (D).

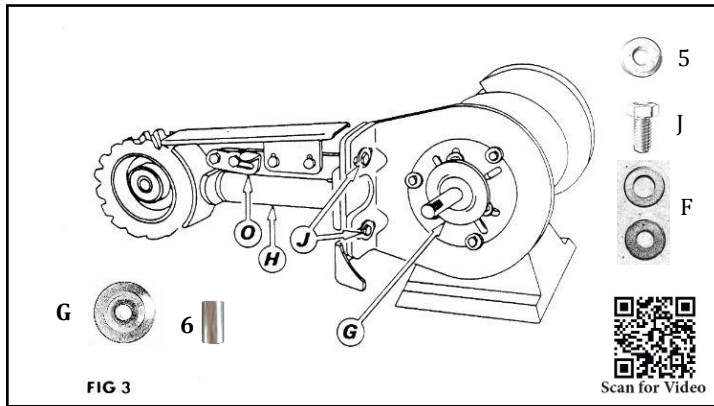

Fit the idler arm (H) using 5/16" diameter bolts (J) and washers (5) provided. Fit one of the flanges (G) provided in the kit, that suits either 1/2" or 5/8" diameter shaft size and check that it clears heads of bolts (Fig 1: B). If there is interference, use either 1/2" or 5/8" diameter washer (pictured above and in Fig 2: F) behind the flange. The drive pulley (Fig 4: K) comes with a 5/8" bore, there is a 1/2" steel bush (6) provided for smaller shafts. **NOTE:** The 4" Drive Pulley in Multitool models 364 & 484 can be bored to a maximum of 1".

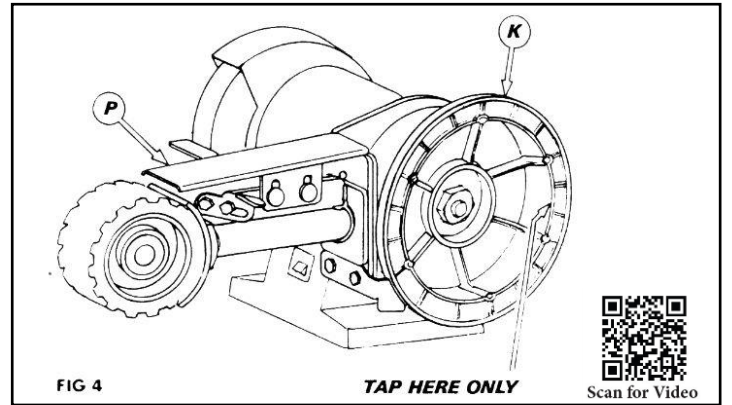

Fit the Drive Pulley (K) by sliding over the shaft of the grinder. Fit tightly against the flange. Use 1/2" or 5/8" diameter washer (Fig 3. F) under the nut and tighten with a socket spanner. If disc face does not run true, tap gently on the inside edge of rim only. **CAUTION:** Tap only with a leather or rubber hammer to avoid any damage that would void warranty on this component. **NOTE:** A poor quality nut on the grinders spindle may prevent pulley from being trued up. If this is the case replace the nut.

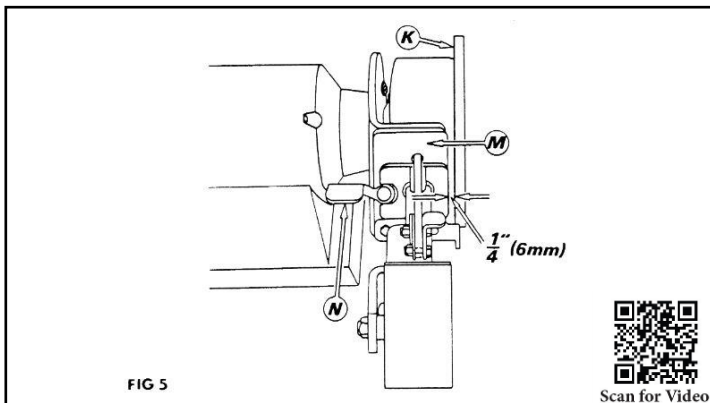

Idler arm Cam plate (M) must now be set 1/4" (6mm) clear of inside edge of the drive pulley (Fig 4. K) Slots are provided under 5/16" bolts (Fig 3. J) for this adjustment. Set tracking lever (N) in mid or horizontal position. Fit the belt and release spring loaded contact wheel by lifting the catch (Fig 3. O) **NOTE:** It is not necessary to remove the platen as in Figs 5 & 6. This has been removed for clarity and instruction only. N.B There will always be some parts left over after fitting.

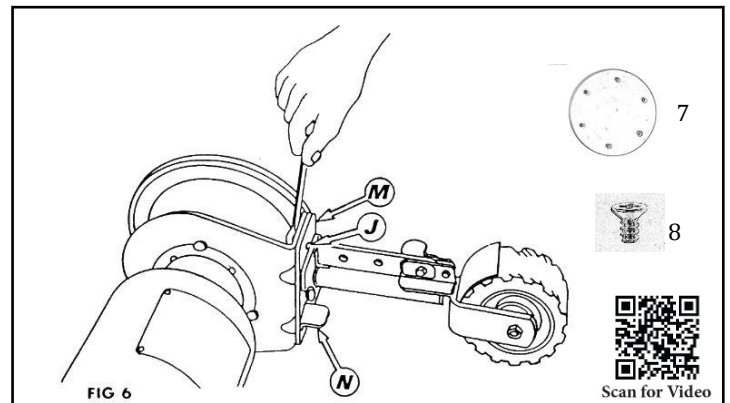

Pull the belt over a few revolutions by hand, if the belt wanders towards the drive pulley (K), loosen the top bolt (J) and tap the top of the cam plate (M) in small amount towards the drive pulley. If the belt moves towards the grinder, tap the top of cam plate (M) towards the grinder. When the belt runs evenly on the contact wheel, re-tighten bolt (J), turn grinder on to check. Final tracking adjustments can be done with the tracking lever (Fig 5. N). Pulling the tracking lever down moves belt to the left, up moves the belt to the right. Fit the cover plate using counter sunk screws provided (pictured above 7 & 8). Clean face of cover disc with a solvent and fit the adhesive backed abrasive disc provided.